



TRANE®

Downflow/Horizontal Right or Downflow/Horizontal Left 2-Stage, Variable Speed Gas-Fired Furnace

XV 80

TDD060,080,
100,120R9V

Two-Stage Fan Assisted
Combustion System

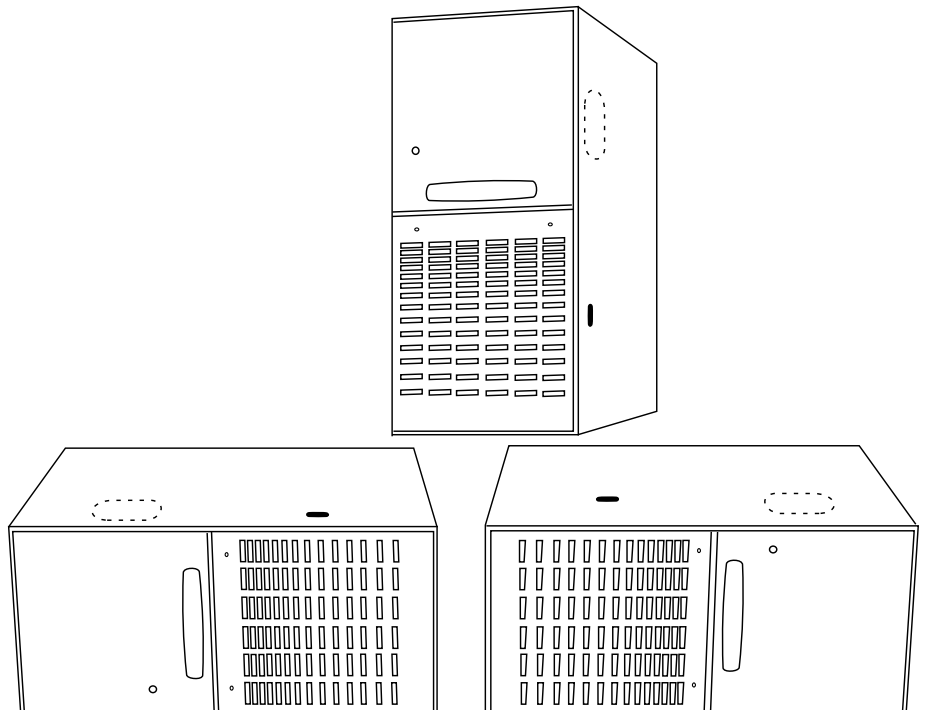

PUB. NO. 22-1673-06



General Features

NATURAL GAS MODELS

Central Heating furnace designs are certified by the American Gas Association for both natural and L.P. gas. Limit setting and rating data were established and approved under standard rating conditions using American National Standards Institute standards.

SAFE OPERATION

The Integrated System Control has solid state devices, which continuously monitor for presence of flame, when the system is in the heating mode of operation. Dual solenoid combination gas valve and regulator provide extra safety.

QUICK HEATING

Durable, cycle tested, heavy gauge **aluminized steel heat exchanger** quickly transfers heat to provide warm conditioned air to the structure.

BURNERS

Multiport Inshot burners will give years of quiet and efficient service. All models can be converted to **L.P. gas**.

INTEGRATED SYSTEM CONTROL

Exclusively designed operational program provides total control of furnace limit sensors, blowers, gas valve, flame control and includes self diagnostics for ease of service. Also contains connection points for E.A.C./humidifier.

AIR DELIVERY

The variable speed, direct drive blower motor, has sufficient airflow for most heating and cooling requirements, will

switch from heating to cooling speeds on demand from room thermostat. The blower door safety switch will prevent or terminate furnace operation when the blower door is removed.

STYLING

Heavy gauge steel and "wrap-around" cabinet construction is used in the cabinet with baked-on enamel finish for strength and beauty. The heat exchanger section of the cabinet is completely lined with foil faced fiberglass insulation. This results in quiet and efficient operation due to the excellent acoustical and insulating qualities of fiberglass.

FEATURES AND GENERAL OPERATION

The XV 80 High Efficiency Gas Furnaces employs an adaptive Hot Surface Ignition system, which eliminates the waste of a constant burning pilot. The integrated system control lights the main burners upon a demand for heat from the room thermostat. Complete front service access.

- a. Low energy power venter
- b. Vent proving pressure switch.



Contents

Feature Summary	2
Features and Benefits	4
Standard Equipment	
Optional Equipment	
General Data	6
TDD060R9V3F	
TDD080R9V3F	
TDD100R9V5F	
TDD120R9V5F	
Performance Data	8
Electrical Data	12
Field Wiring	13
Dimensions	16



Features and Benefits

XV 80 DOWNFLOW/HORIZONTAL RIGHT or LEFT STANDARD EQUIPMENT

- Convertible to horizontal
- Power supply 115/1/60
- 2-stage gas valve
- 2-speed venter
- Hot surface igniter
- Integrated system control
- Attractive color accents
- Heavy gauge aluminized steel heat exchanger
- Soft start - gradually cycles on airflow
- Direct drive variable speed motor
- Blower door safety switch
- Multiport Inshot burners
- Complete front service access
- Molded plastic nameplate
- Comfort-R™
- Slide out blower assembly
- Adjustable fan off times
- Common vent capability
- Cleanable high velocity filters
- Heavy gauge reinforced wrap-around steel cabinet
- Super quiet performance
- Optional L.P. conversion kit
- Left/right gas connection



Features and Benefits

XV 80 OPTIONAL EQUIPMENT

Thermostat, Mechanical 2-Stage Heating/1-Stage Cooling	TAYSTAT241 []
Thermostat, Heating/Cooling Single Stage (Mounts Horizontally)	AY28X092 []
Thermostat, Heating/Cooling Single Stage (Mounts Vertically)	BAYSTAT305 []
Thermostat, Electronic Programmable 2-Stage Heating/2-Stage Cooling	TAYSTAT302C []
Thermostat, Electronic Programmable 1-Stage Heating/1-Stage Cooling	TAYSTAT300C []
Thermostat, Electronic 1Htg/1Clg (Non-Prog)	TAYSTAT370 []
Thermostat, Electronic 1Htg/1Clg (Prog-5/2)	TAYSTAT340 []
Propane Conversion Kit	BAYLPKT210A []
Electronic Air Filter, "Perfect Fit" High Efficiency (17-1/2" Wide Gas Furnace)	TFM175A9FR0 []
Electronic Air Filter, "Perfect Fit" High Efficiency (21" Wide Gas Furnace)	TFM210A9FR0 []
Electronic Air Filter, "Perfect Fit" High Efficiency (24-1/2" Wide Gas Furnace)	TFM245A9FR0 []
Electronic Air Filter, "Perfect Fit" Standard Efficiency (17-1/2" Wide Gas Furnace)	TFP175A9FR0 []
Electronic Air Filter, "Perfect Fit" Standard Efficiency (21" Wide Gas Furnace)	TFP210A9FR0 []
Electronic Air Filter, "Perfect Fit" Standard Efficiency (24-1/2" Wide Gas Furnace)	TFP245A9FR0 []
Coil Enclosure (17-1/2" Wide Cabinets)	BAYCLE17A1722A []
Coil Enclosure (21" Wide Cabinets)	BAYCLE21A2130A []
Coil Enclosure (24-1/2" Wide Cabinets)	BAYCLE24A2430A []
Subbase	BAYBASE205 []
Filter Access Door Kit	BAYFLTR206 []
High Altitude Switch	BAYHALT249 []
Masonry Chimney Vent Kit	BAYVENT800B []



General Data

PRODUCT SPECIFICATIONS ①

MODEL	TDD060R9V3F	TDD080R9V3F
TYPE	Downflow / Horizontal	Downflow / Horizontal
RATINGS ②		
1st Stage Input BTUH	39,000	52,000
1st Stage Capacity BTUH (ICS) ③	31,200	41,600
2nd Stage Input BTUH	60,000	80,000
2nd Stage Capacity BTUH (ICS) ③	48,000	63,000
AFUE (ICS)	80.0	80.0
Temp. rise (Min.-Max.) °F.	35 - 65	35 - 65
BLOWER DRIVE	Direct	Direct
Diameter - Width (In.)	10 x 7	10 x 7
No. Used	1	1
Speeds (No.)	Variable	Variable
CFM vs. in. w.g.	See Airflow Table	See Airflow Table
Motor HP	1/2	1/2
R.P.M.	Variable	Variable
Volts / Ph / Hz	115/1/60	115/1/60
COMBUSTION FAN - Type	Centrifugal	Centrifugal
Drive - No. Speeds	Direct - 2	Direct - 2
Motor HP - RPM	1/50 - 3000	1/50 - 3000
Volts / Ph / Hz	115/1/60	115/1/60
FLA	1.0	1.0
FILTER — Furnished?	Yes	Yes
Type Recommended	High Velocity	High Velocity
Hi Vel. (No.-Size-Thk.)	2 - 14 x 20 - 1 in.	2 - 14 x 20 - 1 in.
VENT — Size (in.)	4 Round	4 Round
HEAT EXCHANGER		
Type-Fired	Alum. Steel - Type 1	Alum. Steel - Type 1
-Unfired		
Gauge (Fired)	20	20
ORIFICES — Main		
Nat. Gas. Qty. — Drill Size	3 — 45	4 — 45
L.P. Gas Qty. — Drill Size	3 — 56	4 — 56
GAS VALVE	Redundant - Two Stage	Redundant - Two Stage
PILOT SAFETY DEVICE		
Type	Hot Surface Ignition	Hot Surface Ignition
BURNERS — Type	Multiport Inshot	Multiport Inshot
Number	3	4
POWER CONN. — V / Ph / Hz ④	115/1/60	115/1/60
Ampacity (In Amps)	10.5	10.5
Max. Overcurrent Protection (Amps)	15	15
PIPE CONN. SIZE (IN.)	1/2	1/2
DIMENSIONS	H x W x D	H x W x D
Crated (In.)	41-3/4 x 19-1/2 x 30-1/2	41-3/4 x 19-1/2 x 30-1/2
WEIGHT		
Shipping (Lbs.) / Net (Lbs)	140 / 129	146 / 135

① Central Furnace heating designs are certified by AGA and CSA.

② For U.S. applications, above input ratings (BTUH) are up to 2,000 feet, derate 4% per 1,000 feet for elevations above 2,000 feet above sea level. For Canadian applications, above input ratings (BTUH) are up to 4,500 feet, derate 4% per 1,000 feet for elevations above 4,500 feet above sea level.

③ Based on U.S. government standard tests.

④ The above wiring specifications are in accordance with National Electrical Code; however, installations must comply with local codes.



General Data

PRODUCT SPECIFICATIONS ①

MODEL	TDD100R9V5F	TDD120R9V5F
TYPE	Downflow / Horizontal	Downflow / Horizontal
RATINGS ②		
1st Stage Input BTUH	65,000	78,000
1st Stage Capacity BTUH (ICS) ③	52,000	62,400
2nd Stage Input BTUH	100,000	120,000
2nd Stage Capacity BTUH (ICS) ③	81,000	95,000
AFUE (ICS)	80.0	80.0
Temp. rise (Min.-Max.) °F.	35 - 65	35 - 65
BLOWER DRIVE	Direct	Direct
Diameter - Width (In.)	11 x 10	11 x 10
No. Used	1	1
Speeds (No.)	Variable	Variable
CFM vs. in. w.g.	See Airflow Table	See Airflow Table
Motor HP	1	1
R.P.M.	Variable	Variable
Volts / Ph / Hz	115/1/60	115/1/60
COMBUSTION FAN - Type	Centrifugal	Centrifugal
Drive - No. Speeds	Direct - 2	Direct - 2
Motor HP - RPM	1/50 - 3000	1/50 - 3000
Volts / Ph / Hz	115/1/60	115/1/60
FLA	1.0	1.15
FILTER — Furnished?	Yes	Yes
Type Recommended	High Velocity	High Velocity
Hi Vel. (No.-Size-Thk.)	2 - 16 x 20 - 1 in.	2 - 16 x 20 - 1 in.
VENT — Size (in.)	4 Round	4 Round
HEAT EXCHANGER		
Type-Fired	Alum. Steel	Alum. Steel
-Unfired		
Gauge (Fired)	20	20
ORIFICES — Main		
Nat. Gas Qty. — Drill Size	5 — 45	6 — 45
L.P. Gas Qty. — Drill Size	5 — 56	6 — 56
GAS VALVE	Redundant - Two Stage	Redundant - Two Stage
PILOT SAFETY DEVICE		
Type	Hot Surface Ignition	Hot Surface Ignition
BURNERS — Type	Multiport Inshot	Multiport Inshot
Number	5	6
POWER CONN. — V / Ph / Hz ④	115/1/60	115/1/60
Ampacity (In Amps)	14.9	15.3
Max. Overcurrent Protection (Amps)	20	20
PIPE CONN. SIZE (IN.)	1/2	1/2
DIMENSIONS	H x W x D	H x W x D
Crated (In.)	41-3/4 x 23 x 30-1/2	41-3/4 x 26-1/2 x 30-1/2
WEIGHT		
Shipping (Lbs.) / Net (Lbs)	166 / 155	197 / 185

① Central Furnace heating designs are certified by AGA and CSA.

② For U.S. applications, above input ratings (BTUH) are up to 2,000 feet, derate 4% per 1,000 feet for elevations above 2,000 feet above sea level. For Canadian applications, above input ratings (BTUH) are up to 4,500 feet, derate 4% per 1,000 feet for elevations above 4,500 feet above sea level.

③ Based on U.S. government standard tests.

④ The above wiring specifications are in accordance with National Electrical Code; however, installations must comply with local codes.



Performance Data

TDD060R9V3F FURNACE HEATING AIRFLOW (CFM) AND POWER (WATTS) VS. EXTERNAL STATIC PRESSURE WITH FILTER									
	AIRFLOW SETTING	DIP SWITCH SETTING			EXTERNAL STATIC PRESSURE				
		SW7	SW8		0.1	0.3	0.5	0.7	0.9
HEATING 1ST STAGE	LOW	ON	ON	CFM	547	593	571	567	544
				TEMP. RISE	53	49	51	51	53
				WATTS	48	80	107	143	170
	MEDIUM **	ON	OFF	CFM	658	664	658	658	652
				TEMP. RISE	44	44	44	44	44
				WATTS	65	92	122	155	197
	HIGH	OFF	OFF	CFM	735	761	761	764	762
				TEMP. RISE	39	38	38	38	38
				WATTS	75	120	155	190	230
HEATING 2ND STAGE	LOW	ON	ON	CFM	743	777	775	783	772
				TEMP. RISE	60	57	57	57	58
				WATTS	75	120	155	195	230
	MEDIUM **	ON	OFF	CFM	874	887	881	894	894
				TEMP. RISE	51	50	50	50	50
				WATTS	105	150	185	230	270
	HIGH	OFF	OFF	CFM	996	1013	1041	1058	1069
				TEMP. RISE	45	44	43	42	42
				WATTS	143	192	250	307	337

TDD060R9V3F FURNACE COOLING AIRFLOW (CFM) AND POWER (WATTS) VS. EXTERNAL STATIC PRESSURE WITH FILTER											
OUTDOOR UNIT SIZE (TONS)	AIRFLOW SETTING	DIP SWITCH SETTING					EXTERNAL STATIC PRESSURE				
		SW1	SW2	SW3	SW4		0.1	0.3	0.5	0.7	0.9
1.5	LOW (350 CFM/TON)	ON	ON	OFF	ON	CFM	533	563	546	534	515
						WATTS	45	75	100	130	160
	NORMAL (400 CFM/TON)	ON	ON	OFF	OFF	CFM	609	627	624	606	607
						WATTS	55	90	115	150	180
	HIGH (450 CFM/TON)	ON	ON	ON	OFF	CFM	664	683	690	687	680
						WATTS	65	95	135	165	200
2	LOW (350 CFM/TON)	OFF	ON	OFF	ON	CFM	693	714	708	706	712
						WATTS	65	105	135	170	210
	NORMAL (400 CFM/TON)	OFF	ON	OFF	OFF	CFM	780	821	813	810	816
						WATTS	85	130	165	205	245
	HIGH (450 CFM/TON)	OFF	ON	ON	OFF	CFM	886	896	901	925	930
						WATTS	110	150	200	250	285
2.5	LOW (350 CFM/TON)	ON	OFF	OFF	ON	CFM	865	882	869	884	885
						WATTS	105	145	185	275	265
	NORMAL (400 CFM/TON)	ON	OFF	OFF	OFF	CFM	977	983	1014	1035	1019
						WATTS	135	180	235	290	330
	HIGH (450 CFM/TON)	ON	OFF	ON	OFF	CFM	1097	1125	1155	1169	1169
						WATTS	170	235	305	350	405
3 **	LOW (350 CFM/TON)	OFF	OFF	OFF	ON	CFM	1006	1034	1056	1072	1067
						WATTS	145	200	255	315	352
	NORMAL ** (400 CFM/TON)	OFF	OFF	OFF	OFF	CFM	1169	1202	1226	1221	1217
						WATTS	215	265	355	390	440
	HIGH (450 CFM/TON)	OFF	OFF	ON	OFF	CFM	1313	1339	1360	1369	1357
						WATTS	290	370	425	500	525

- NOTES:
- **FACTORY SETTING.
 - CONTINUOUS FAN SETTING: HEATING OR COOLING AIRFLOW IS APPROXIMATELY 50% OF SELECTED COOLING VALUE.
 - FOR VARIABLE SPEED: LOW SPEED AIRFLOWS ARE APPROXIMATELY 30% OF LISTED VALUES.
 - LOW 350 CFM/TON IS RECOMMENDED FOR VARIABLE SPEED APPLICATION FOR COMFORT & HUMID CLIMATE SETTING: NORMAL IS 400 CFM/TON: HIGH 450 CFM/TON IS FOR DRY CLIMATE SETTING.



Performance Data

TDD080R9V3F FURNACE HEATING AIRFLOW (CFM) AND POWER (WATTS) VS. EXTERNAL STATIC PRESSURE WITH FILTER									
	AIRFLOW SETTING	DIP SWITCH SETTING			EXTERNAL STATIC PRESSURE				
		SW 7	SW 8		0.1	0.3	0.5	0.7	0.9
HEATING 1ST STAGE	LOW	ON	ON	CFM TEMP. RISE WATTS	775 50 85	750 51 110	700 55 140	685 56 170	680 57 185
	MEDIUM **	ON	OFF	CFM TEMP. RISE WATTS	865 45 110	840 46 140	820 47 175	795 48 210	770 50 235
	HIGH	OFF	OFF	CFM TEMP. RISE WATTS	1010 38 160	980 39 190	970 40 230	940 41 260	915 42 285
HEATING 2ND STAGE	LOW	ON	ON	CFM TEMP. RISE WATTS	1080 55 180	1060 56 220	1035 57 255	1010 59 285	995 60 325
	MEDIUM **	ON	OFF	CFM TEMP. RISE WATTS	1190 50 245	1190 50 290	1170 51 330	1155 51 370	1140 52 410
	HIGH	OFF	OFF	CFM TEMP. RISE WATTS	1345 44 330	1335 44 380	1320 45 425	1310 45 475	1275 46 505

TDD080R9V3F FURNACE COOLING AIRFLOW (CFM) AND POWER (WATTS) VS. EXTERNAL STATIC PRESSURE WITH FILTER											
OUTDOOR UNIT SIZE (TONS)	AIRFLOW SETTING	DIP SWITCH SETTING					EXTERNAL STATIC PRESSURE				
		SW 1	SW 2	SW 3	SW 4		0.1	0.3	0.5	0.7	0.9
2.5	LOW (350 CFM/TON)	OFF	ON	OFF	ON	CFM WATTS	840 105	830 135	830 160	815 220	750 225
	NORMAL (400 CFM/TON)	OFF	ON	OFF	OFF	CFM WATTS	970 140	950 170	940 210	925 245	900 270
	HIGH (450 CFM/TON)	OFF	ON	ON	OFF	CFM WATTS	1085 185	1060 220	1045 260	1015 300	1000 325
3.0	LOW (350 CFM/TON)	ON	OFF	OFF	ON	CFM WATTS	1015 155	995 190	990 230	970 260	920 285
	NORMAL (400 CFM/TON)	ON	OFF	OFF	OFF	CFM WATTS	1150 215	1140 250	1120 305	1100 335	1085 370
	HIGH (450 CFM/TON)	ON	OFF	ON	OFF	CFM WATTS	1290 300	1290 340	1270 390	1260 425	1235 475
3.5 **	LOW (350 CFM/TON)	OFF	OFF	OFF	ON	CFM WATTS	1160 220	1150 265	1140 320	1115 345	1100 385
	NORMAL ** (400 CFM/TON)	OFF	OFF	OFF	OFF	CFM WATTS	1355 330	1340 380	1330 425	1320 470	1280 510
	HIGH (450 CFM/TON)	OFF	OFF	ON	OFF	CFM WATTS	1360 330	1360 380	1315 425	1320 470	1280 510

NOTES:
 1. ** Factory setting
 2. Continuous Fan Setting: Heating or Cooling airflow is approximately 50% of selected Cooling value.
 3. For Variable Speed: low speed airflows are approximately 30% of listed values.
 4. LOW 350 cfm/ton is recommended for Variable Speed application for COMFORT & HUMID CLIMATE setting; NORMAL is 400 cfm/ton; HIGH 450 cfm/ton is for DRY CLIMATE setting



Performance Data

TDD100R9V5F FURNACE HEATING AIRFLOW (CFM) AND POWER (WATTS) VS. EXTERNAL STATIC PRESSURE WITH FILTER									
	AIRFLOW SETTING	DIP SWITCH SETTING			EXTERNAL STATIC PRESSURE				
		SW 7	SW 8		0.1	0.3	0.5	0.7	0.9
HEATING 1ST STAGE	LOW	ON	ON	CFM TEMP. RISE WATTS	890 54 87	870 55 120	855 56 160	850 57 200	825 58 250
	MEDIUM **	ON	OFF	CFM TEMP. RISE WATTS	1100 44 135	1090 44 175	1080 45 225	1070 45 260	1070 45 320
	HIGH	OFF	OFF	CFM TEMP. RISE WATTS	1270 38 195	1290 37 260	1295 37 315	1300 37 365	1300 37 425
HEATING 2ND STAGE	LOW	ON	ON	CFM TEMP. RISE WATTS	1230 60 180	1220 61 220	1250 59 290	1255 59 345	1275 58 410
	MEDIUM **	ON	OFF	CFM TEMP. RISE WATTS	1520 49 295	1550 48 385	1560 47 460	1555 48 525	1530 48 565
	HIGH	OFF	OFF	CFM TEMP. RISE WATTS	1820 41 475	1825 41 570	1825 41 625	1800 41 685	1740 43 695

TDD100R9V5F FURNACE COOLING AIRFLOW (CFM) AND POWER (WATTS) VS. EXTERNAL STATIC PRESSURE WITH FILTER											
OUTDOOR UNIT SIZE (TONS)	AIRFLOW SETTING	DIP SWITCH SETTING					EXTERNAL STATIC PRESSURE				
		SW 1	SW 2	SW 3	SW 4		0.1	0.3	0.5	0.7	0.9
3.0	LOW (350 CFM/TON)	ON	ON	OFF	ON	CFM WATTS	1025 125	1050 165	1035 195	1030 250	1005 285
	NORMAL (400 CFM/TON)	ON	ON	OFF	OFF	CFM WATTS	1185 165	1180 210	1180 250	1190 315	1190 365
	HIGH (450 CFM/TON)	ON	ON	ON	OFF	CFM WATTS	1300 200	1345 280	1355 325	1375 405	1370 450
3.5	LOW (350 CFM/TON)	OFF	ON	OFF	ON	CFM WATTS	1195 165	1185 215	1200 270	1200 320	1190 370
	NORMAL (400 CFM/TON)	OFF	ON	OFF	OFF	CFM WATTS	1360 230	1390 315	1425 380	1420 430	1420 495
	HIGH (450 CFM/TON)	OFF	ON	ON	OFF	CFM WATTS	1560 320	1595 425	1595 460	1595 540	1570 585
4.0	LOW (350 CFM/TON)	ON	OFF	OFF	ON	CFM WATTS	1350 235	1385 300	1410 375	1420 425	1410 495
	NORMAL (400 CFM/TON)	ON	OFF	OFF	OFF	CFM WATTS	1575 340	1615 420	1625 495	1610 545	1585 595
	HIGH (450 CFM/TON)	ON	OFF	ON	OFF	CFM WATTS	1800 480	1795 555	1790 620	1760 670	1690 675
5.0 **	LOW (350 CFM/TON)	OFF	OFF	OFF	ON	CFM WATTS	1745 440	1760 515	1755 595	1735 640	1670 660
	NORMAL ** (400 CFM/TON)	OFF	OFF	OFF	OFF	CFM WATTS	2010 630	2000 700	1940 745	1865 740	1760 725
	HIGH (450 CFM/TON)	OFF	OFF	ON	OFF	CFM WATTS	2205 830	2130 835	2015 800	1890 760	1740 720

NOTES:

- ** Factory setting
- Continuous Fan Setting: Heating or Cooling airflow is approximately 50% of selected Cooling value.
- For Variable Speed: low speed airflows are approximately 30% of listed values.
- LOW 350 cfm/ton is recommended for Variable Speed application for COMFORT & HUMID CLIMATE setting; NORMAL is 400 cfm/ton; HIGH 450 cfm/ton is for DRY CLIMATE setting



Performance Data

TDD120R9V5F FURNACE HEATING AIRFLOW (CFM) AND POWER (WATTS) VS. EXTERNAL STATIC PRESSURE WITH FILTER									
	AIRFLOW SETTING	DIP SWITCH SETTING			EXTERNAL STATIC PRESSURE				
		SW 7	SW 8		0.1	0.3	0.5	0.7	0.9
HEATING 1ST STAGE	LOW	ON	ON	CFM TEMP. RISE WATTS	970 60 85	990 58 140	980 59 180	955 61 210	930 62 255
	MEDIUM **	ON	OFF	CFM TEMP. RISE WATTS	1120 52 120	1140 51 170	1115 52 215	1120 52 270	1120 52 315
	HIGH	OFF	OFF	CFM TEMP. RISE WATTS	1240 47 150	1240 47 210	1240 47 250	1240 47 300	1240 47 360
HEATING 2ND STAGE	LOW	ON	ON	CFM TEMP. RISE WATTS	1360 65 190	1380 64 250	1400 63 315	1425 62 400	1430 62 430
	MEDIUM **	ON	OFF	CFM TEMP. RISE WATTS	1570 57 275	1620 55 370	1640 54 440	1650 54 480	1635 54 560
	HIGH	OFF	OFF	CFM TEMP. RISE WATTS	1720 52 360	1735 51 425	1760 51 515	1760 51 585	1760 51 650

TDD120R9V5F FURNACE COOLING AIRFLOW (CFM) AND POWER (WATTS) VS. EXTERNAL STATIC PRESSURE WITH FILTER											
OUTDOOR UNIT SIZE (TONS)	AIRFLOW SETTING	DIP SWITCH SETTING					EXTERNAL STATIC PRESSURE				
		SW 1	SW 2	SW 3	SW 4		0.1	0.3	0.5	0.7	0.9
3.5	LOW (350 CFM/TON)	OFF	ON	OFF	ON	CFM WATTS	1200 150	1200 185	1185 235	1210 290	1210 350
	NORMAL (400 CFM/TON)	OFF	ON	OFF	OFF	CFM WATTS	1355 190	1400 265	1420 335	1445 385	1445 440
	HIGH (450 CFM/TON)	OFF	ON	ON	OFF	CFM WATTS	1535 255	1580 345	1600 415	1620 490	1600 530
4.0	LOW (350 CFM/TON)	ON	OFF	OFF	ON	CFM WATTS	1350 190	1370 250	1400 320	1415 385	1420 445
	NORMAL (400 CFM/TON)	ON	OFF	OFF	OFF	CFM WATTS	1570 275	1600 350	1630 425	1640 500	1630 560
	HIGH (450 CFM/TON)	ON	OFF	ON	OFF	CFM WATTS	1800 400	1800 450	1815 540	1820 610	1810 670
5.0 **	LOW (350 CFM/TON)	OFF	OFF	OFF	ON	CFM WATTS	1725 350	1750 440	1770 500	1790 580	1775 650
	NORMAL ** (400 CFM/TON)	OFF	OFF	OFF	OFF	CFM WATTS	1970 515	2015 615	2035 700	2010 775	1960 800
	HIGH (450 CFM/TON)	OFF	OFF	ON	OFF	CFM WATTS	2260 730	2250 830	2215 885	2100 860	1975 810

NOTES:

- ** Factory setting
- Continuous Fan Setting: Heating or Cooling airflow is approximately 50% of selected Cooling value.
- For Variable Speed: low speed airflows are approximately 30% of listed values.
- LOW 350 cfm/ton is recommended for Variable Speed application for COMFORT & HUMID CLIMATE setting; NORMAL is 400 cfm/ton; HIGH 450 cfm/ton is for DRY CLIMATE setting

Electrical Data

SCHEMATIC DIAGRAMS FOR GAS FURNACES

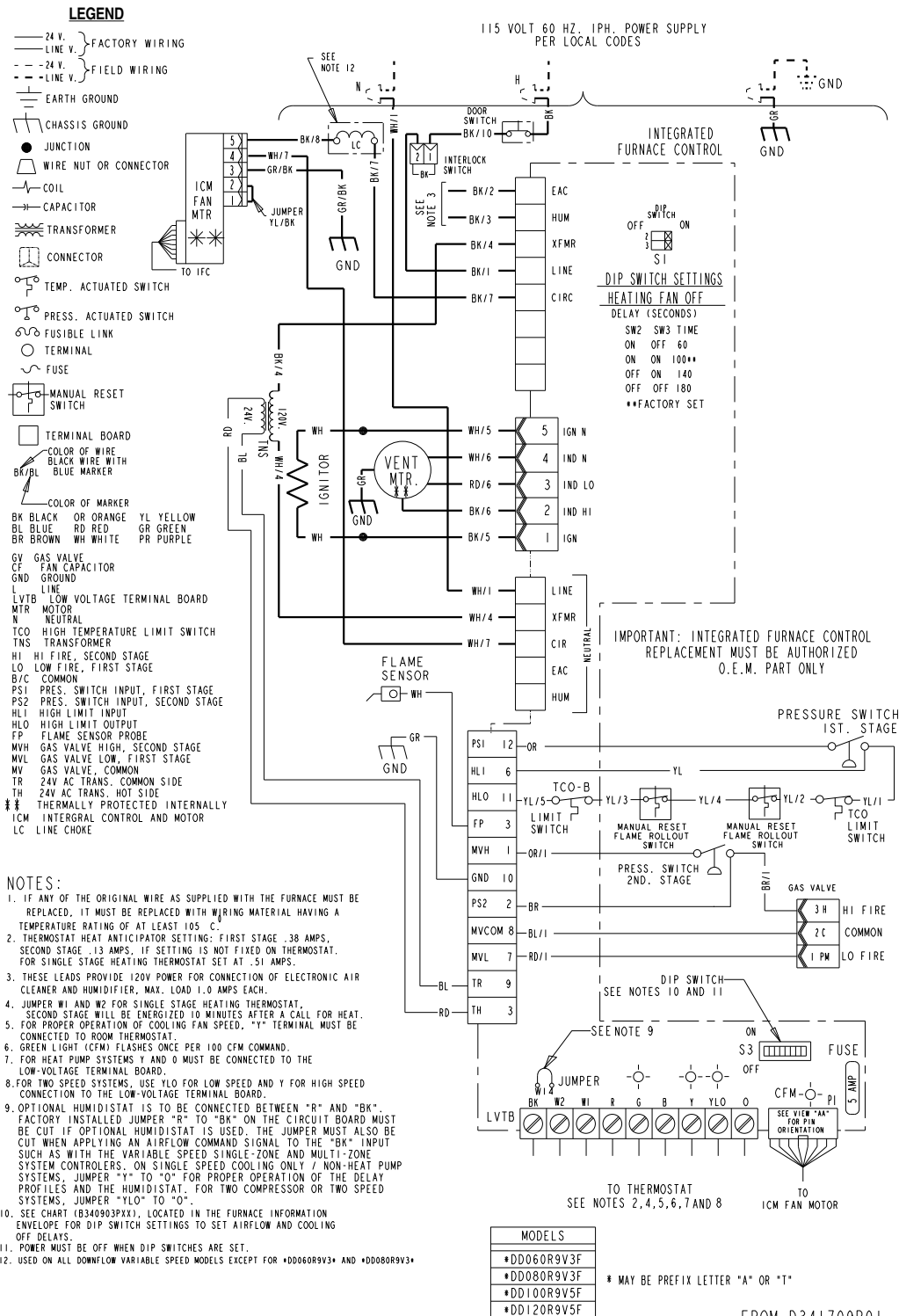

Field Wiring

FIELD WIRING DIAGRAM FOR SINGLE STAGE HEATING ONLY

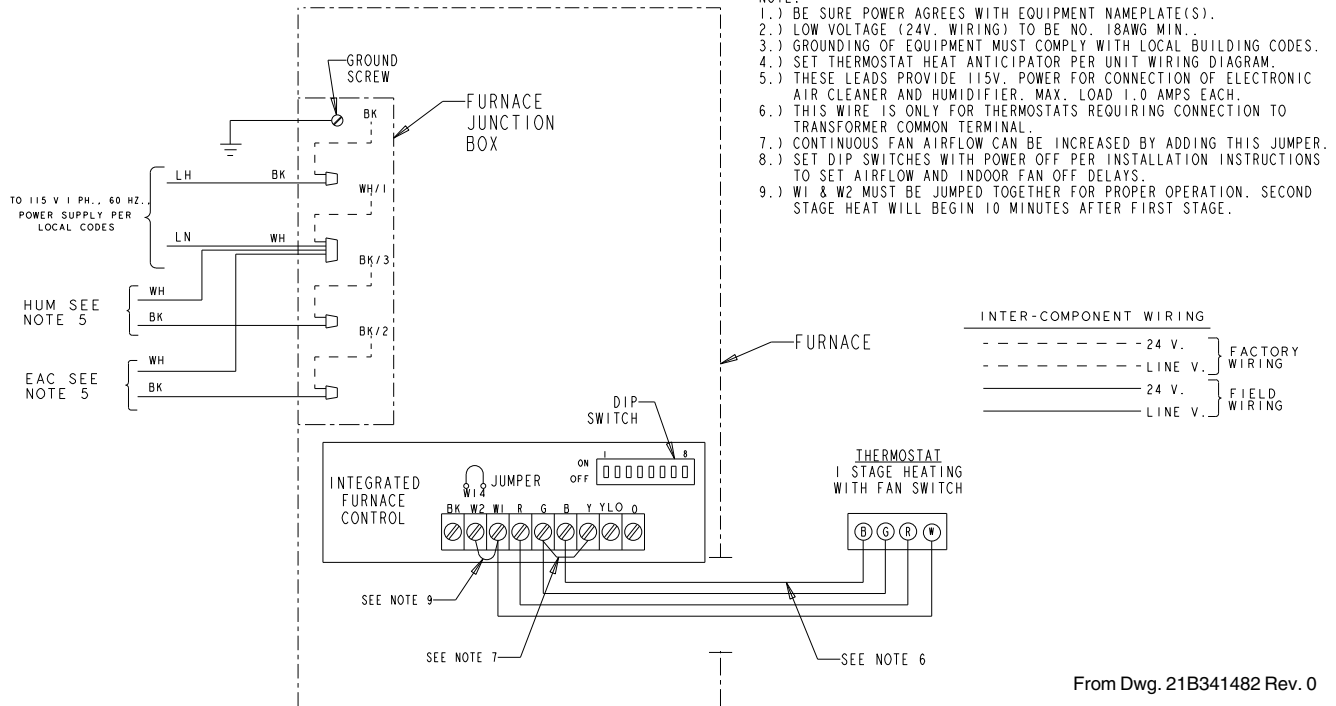

FIELD WIRING DIAGRAM FOR TWO STAGE HEATING

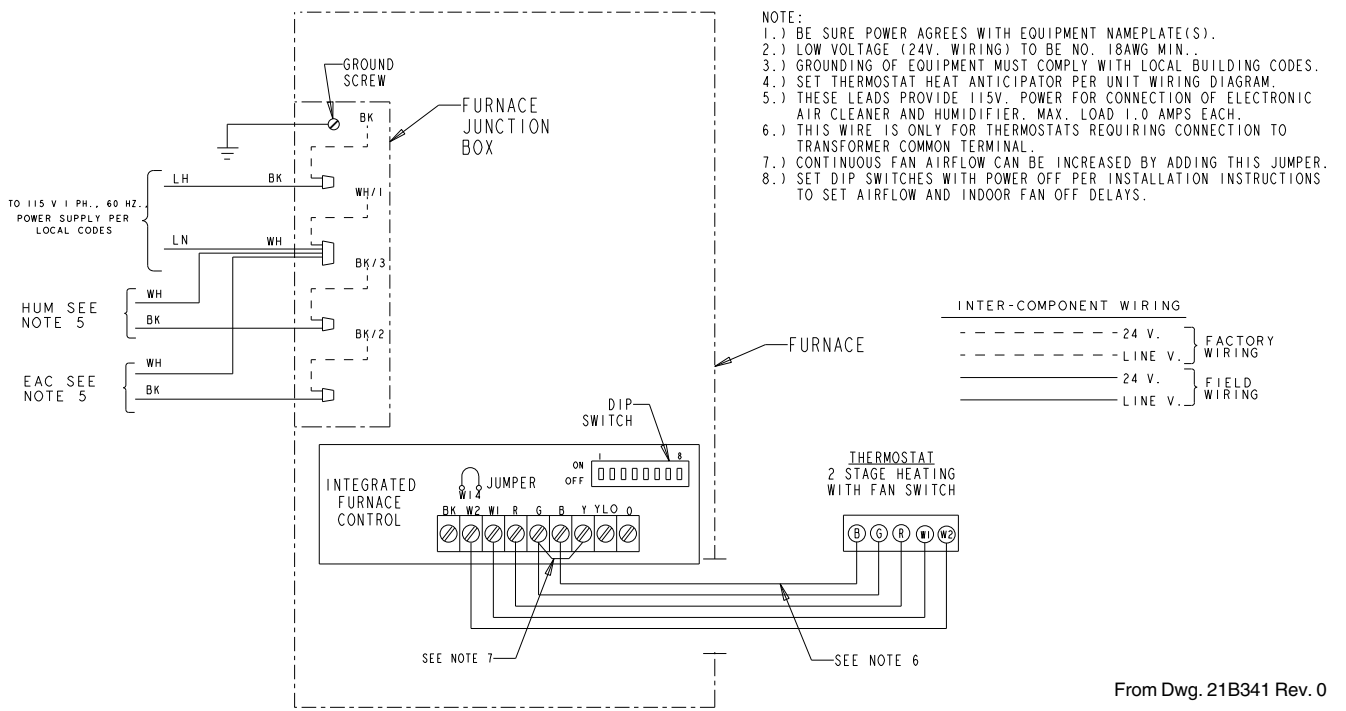

Field Wiring

FIELD WIRING DIAGRAM FOR SINGLE STAGE HEATING WITH SINGLE STAGE COOLING (OUTDOOR SECTION WITHOUT TRANSFORMER)

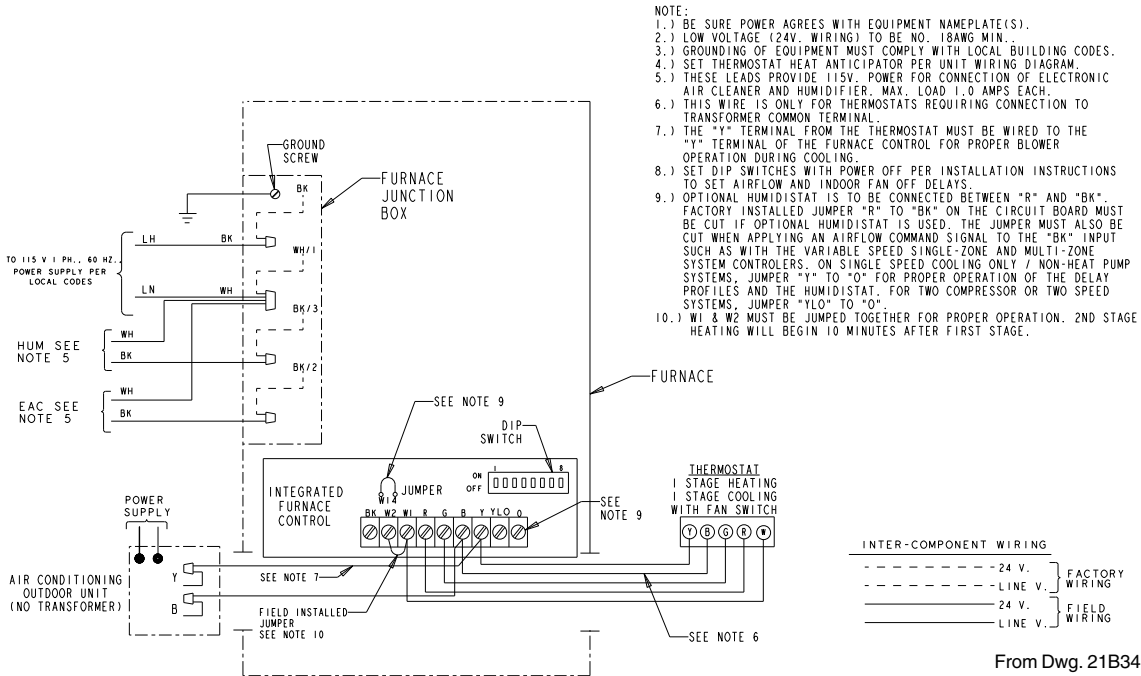

FIELD WIRING DIAGRAM FOR TWO STAGE HEATING WITH SINGLE STAGE COOLING (OUTDOOR SECTION WITHOUT TRANSFORMER)

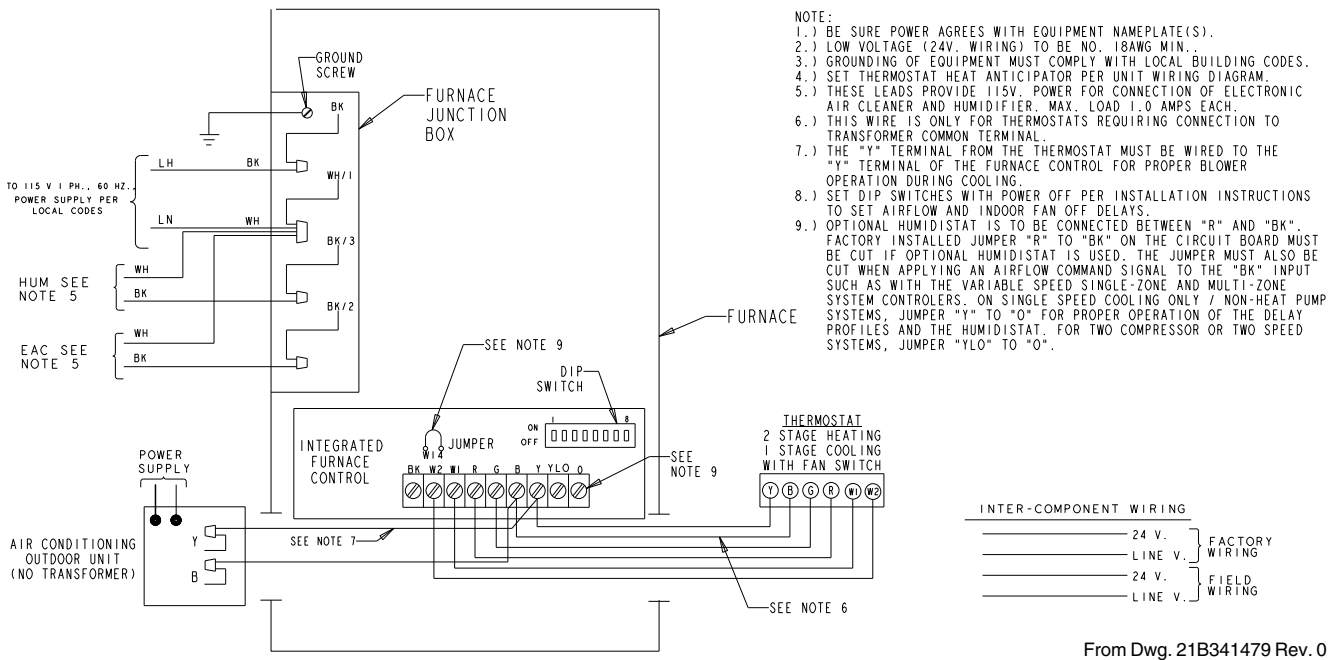

Field Wiring

FIELD WIRING DIAGRAM FOR TWO STAGE HEATING WITH TWO STAGE COOLING (OUTDOOR SECTION WITHOUT TRANSFORMER)

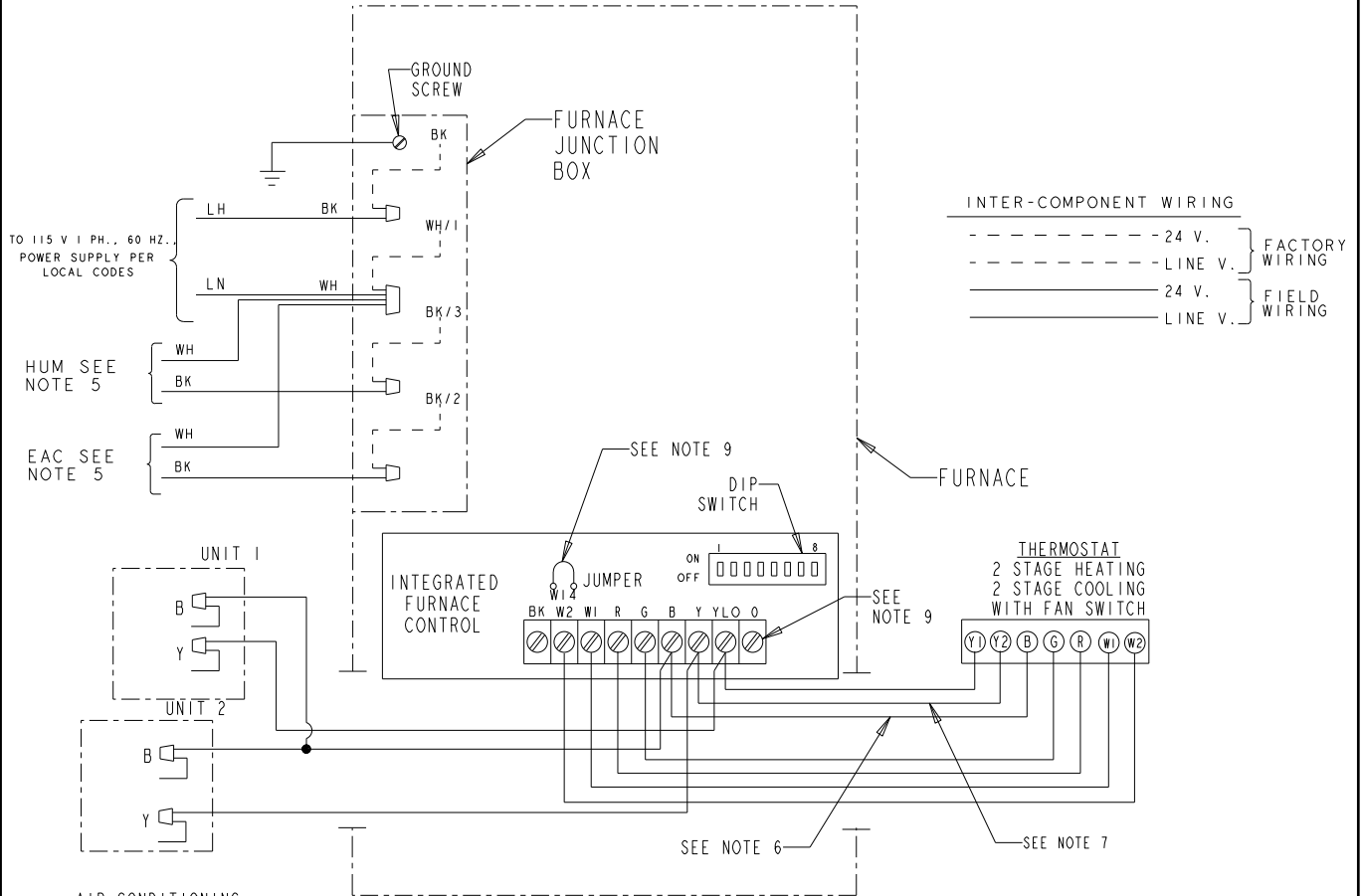

NOTE:

- 1.) BE SURE POWER AGREES WITH EQUIPMENT NAMEPLATE(S).
- 2.) LOW VOLTAGE (24V. WIRING) TO BE NO. 18AWG MIN..
- 3.) GROUNDING OF EQUIPMENT MUST COMPLY WITH LOCAL BUILDING CODES.
- 4.) SET THERMOSTAT HEAT ANTICIPATOR PER UNIT WIRING DIAGRAM.
- 5.) THESE LEADS PROVIDE 115V. POWER FOR CONNECTION OF ELECTRONIC AIR CLEANER AND HUMIDIFIER. MAX. LOAD 1.0 AMPS EACH.
- 6.) THIS WIRE IS ONLY FOR THERMOSTATS REQUIRING CONNECTION TO TRANSFORMER COMMON TERMINAL.
- 7.) THE "Y2" TERMINAL FROM THE THERMOSTAT MUST BE WIRED TO THE "Y" TERMINAL OF THE FURNACE CONTROL FOR PROPER BLOWER OPERATION DURING COOLING.
- 8.) SET DIP SWITCHES WITH POWER OFF PER INSTALLATION INSTRUCTIONS TO SET AIRFLOW AND INDOOR FAN OFF DELAYS.
- 9.) OPTIONAL HUMIDISTAT IS TO BE CONNECTED BETWEEN "R" AND "BK". FACTORY INSTALLED JUMPER "R" TO "BK" ON THE CIRCUIT BOARD MUST BE CUT IF OPTIONAL HUMIDISTAT IS USED. THE JUMPER MUST ALSO BE CUT WHEN APPLYING AN AIRFLOW COMMAND SIGNAL TO THE "BK" INPUT SUCH AS WITH THE VARIABLE SPEED SINGLE-ZONE AND MULTI-ZONE SYSTEM CONTROLLERS. ON SINGLE SPEED COOLING ONLY / NON-HEAT PUMP SYSTEMS, JUMPER "Y" TO "O" FOR PROPER OPERATION OF THE DELAY PROFILES AND THE HUMIDISTAT. FOR TWO COMPRESSOR OR TWO SPEED SYSTEMS, JUMPER "YLO" TO "O".

From Dwg. 21B341490 Rev. 0

Dimensions

TDD-R9V OUTLINE DRAWING (ALL DIMENSIONS ARE IN INCHES)

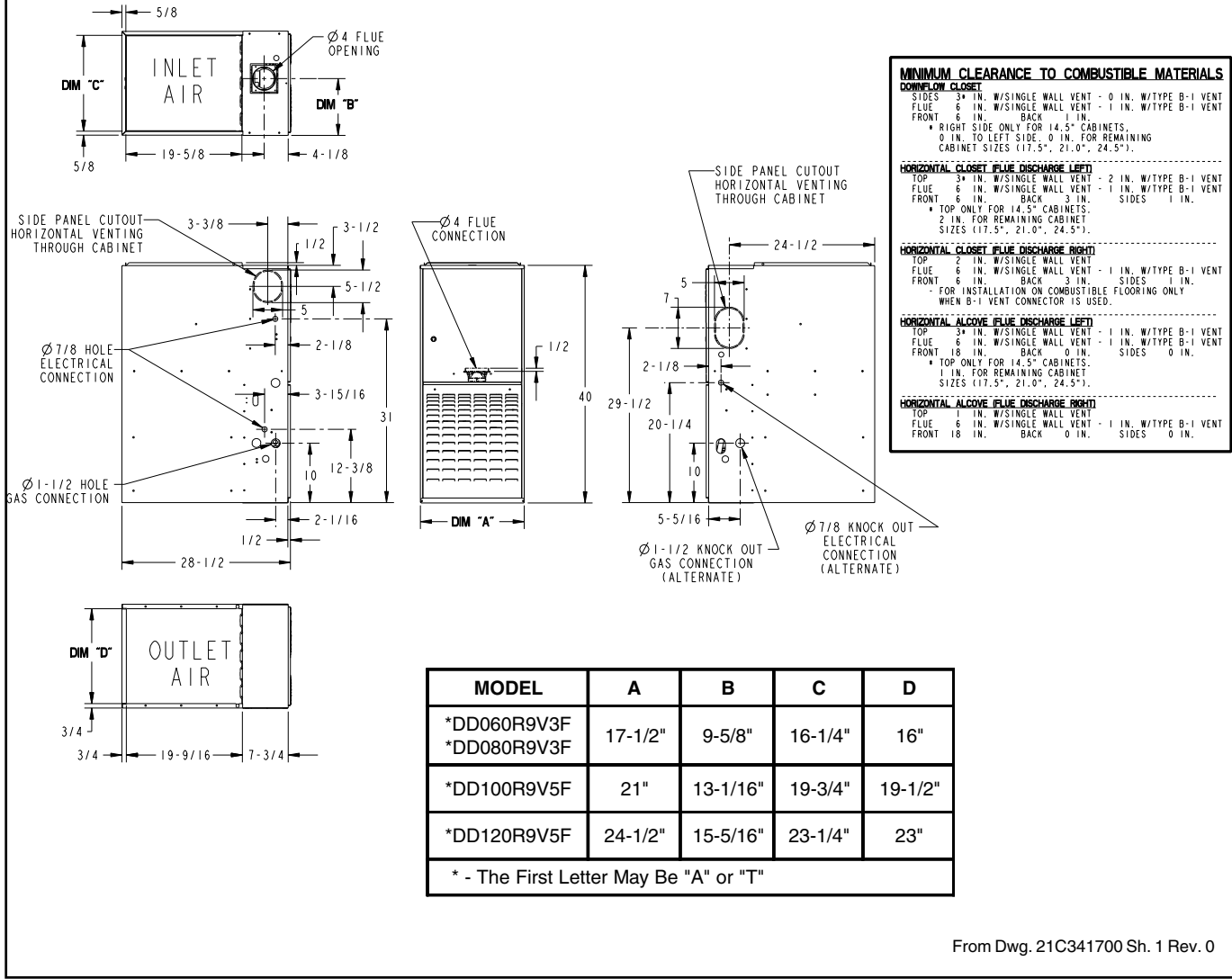

MODEL	A	B	C	D
*DD060R9V3F	17-1/2"	9-5/8"	16-1/4"	16"
*DD080R9V3F				
*DD100R9V5F	21"	13-1/16"	19-3/4"	19-1/2"
*DD120R9V5F	24-1/2"	15-5/16"	23-1/4"	23"

* - The First Letter May Be "A" or "T"

From Dwg. 21C341700 Sh. 1 Rev. 0



Trane
6200 Troup Highway
Tyler, TX 75707
www.trane.com

Since Trane has a policy of continuous product improvement, it reserves the right to change design and specifications without notice.